

CardMac-NB

Business Card Slitter

by AKILES

IMPORTANT

- Only feed **one sheet at a time**.
- Only use paper or cardstock to a maximum thickness of **0.3 mm** (12 mil) or weight of **140 lb** (300gsm).
- Avoid placing fingers or foreign objects into the openings or cutting slots. This can result in injury or damage to the machine.

SAFETY INFORMATION

- Read and understand all operating instructions and safety information before using the machine.
- Observe all warnings and instructions marked on the machine.
- Install the machine securely on a stable surface.
- If the machine does not operate normally, contact your local reseller or service agent for help.
- There are no user serviceable parts inside the machine.
- Do not remove any covers, modify or change any part of the machine. Doing so will void your warranty.

OPERATING INSTRUCTIONS

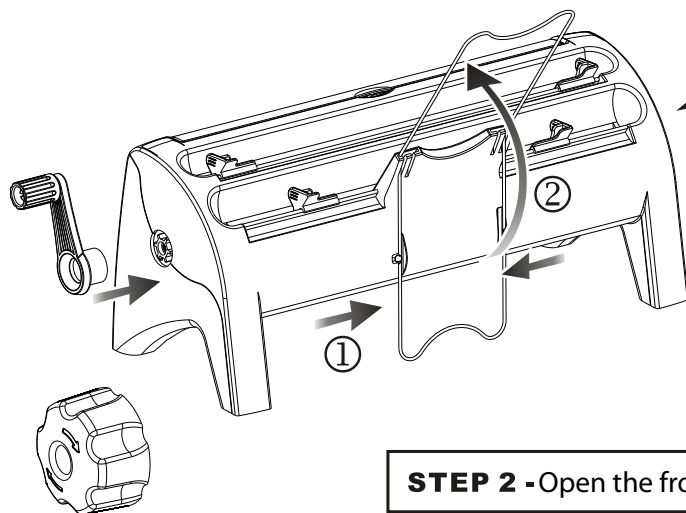

STEP 1 - Squeeze and flip the metal wire upward into the working position. Install one of the two manual handles into the side gear of the **CardMac**.

STEP 2 - Open the front cover.

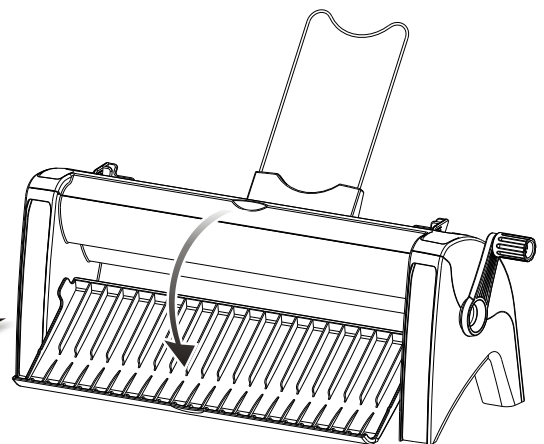

STEP 3 - Insert paper/cardstock into the rear feed tray (**1st cut**). Align the paper/cardstock with the roller blades by adjusting the paper guides on both sides. Turn the manual handle to trim the paper/cardstock into 2 strips.

STEP 4 - Insert one strip into the front feed tray (**2nd cut**). Again, align the strip with the roller blades by adjusting the paper guides on both sides. Be sure to slit the strip one at a time. Turn the manual handle to get finished cards. Repeat this step for other strips to create your business cards.

